



Features

- Small bleed across relief seat assures fast response to small signals
- Multiple inputs allow versatility in process control
- Adjustable Bias Range from -18 to +15 psig permits variation in output
- Two gauge ports located 90° from supply and outlet ports, allows versatility in installation
- Line or Panel Mounting

Operating Principles

The Model 22 Pneumatic Computing Relay is a highly versatile control valve designed to perform a number of specialized functions, including averaging, differential, inverting, and totalizing. This high quality unit, which offers up to four inputs as well as positive and negative biasing over a broad range, is available in several configurations to meet most application requirements.

The combination of multiple configuration options and accurate response characteristics make the Model 22 the ideal choice in a variety of applications with specific input/output requirements such as override or multi-element control, or as an ON-OFF valve.

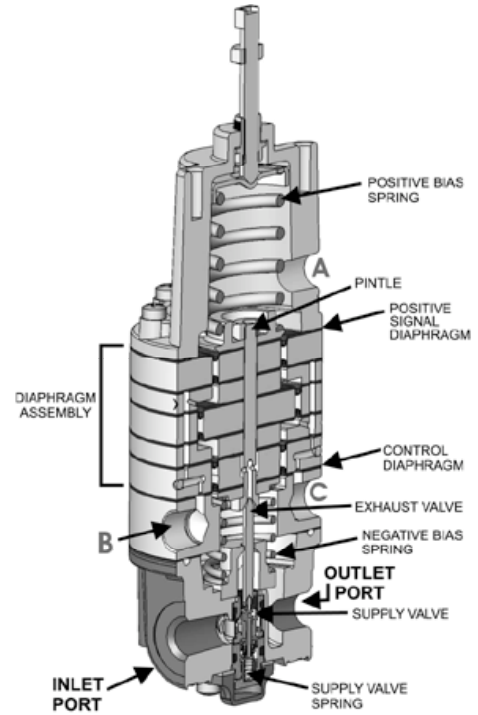

D
Model
22

For Models: 22112, 22113, 22212, 22213, 22222, 22223, 22312

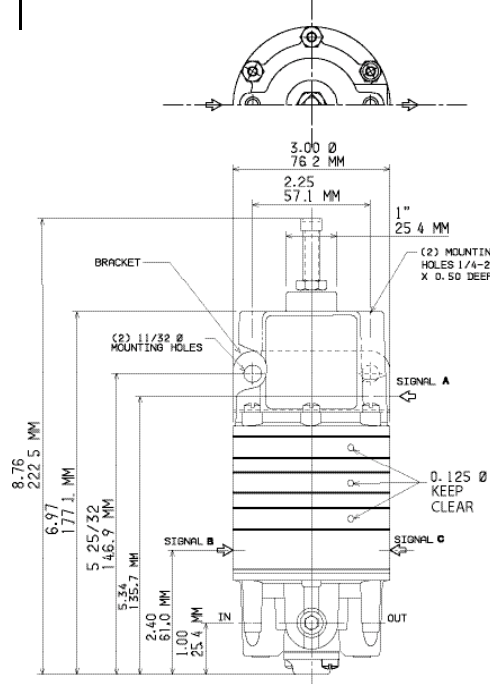

For Models: 22142 & 22422

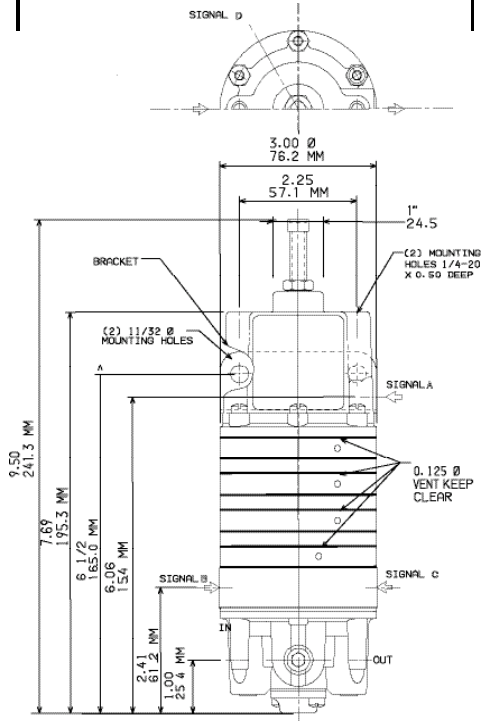

Cross Section

The diagrams show some typical functions and modes of operation for the Model 22. In the equation associated with the diaphragms, P =Output Pressure and A , B , and C =Signal Pressures. K , the constant, is provided by the biasing springs, and is adjustable over a range of -18 psig to +30 psig. S =Supply Pressure

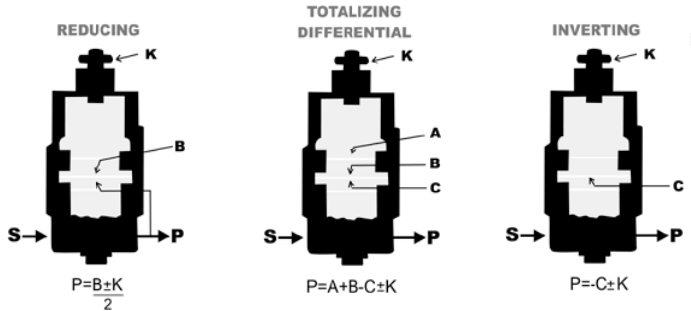
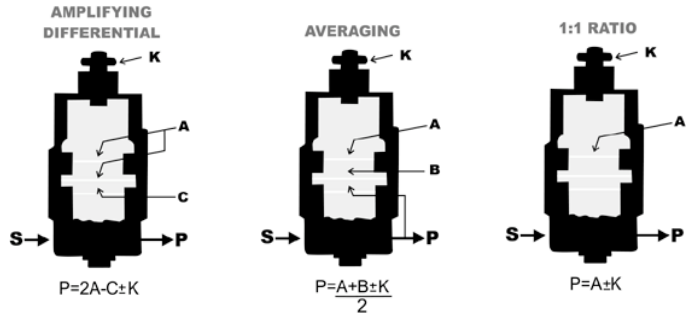
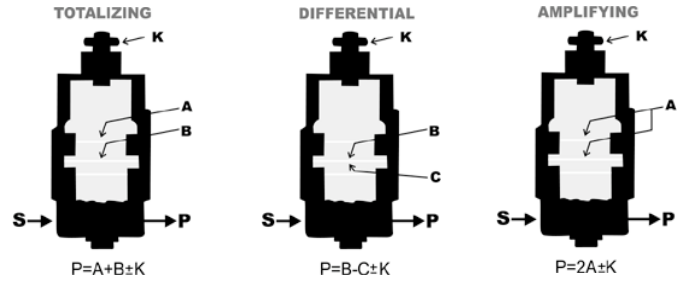
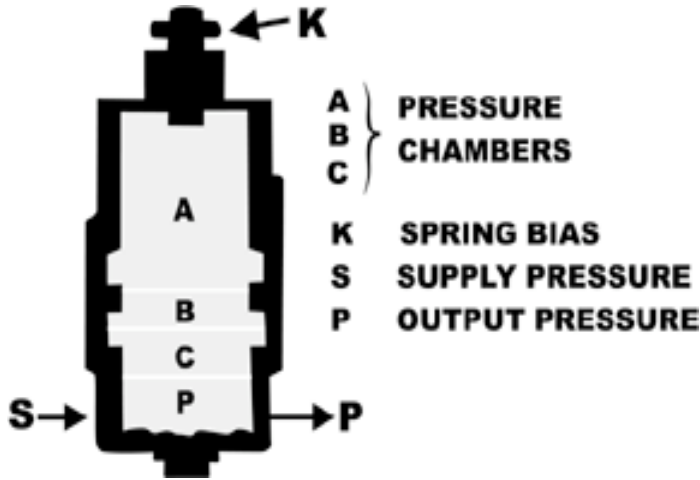

When used as an ON-OFF valve, the Model 22 may open or close a pneumatic circuit, moving rapidly to a full open or a full closed position when signal pressures deviate from set point. In the full open position, the valve passes full supply pressure without modulation or regulation. The function is achieved by connecting output pressure to signal chamber **A**. This connection forms a feedback loop so that, once flow is started, the valve is driven wide open. The relay always goes full open or full closed when conditions are as shown in the diagrams.

NOTE:
Relays reflecting functions identified with prefix numbers 223, 224, 225 and 226 are not shown in this catalog sheet. These units are equipped with additional diaphragms to enable the handling of added signal inputs.

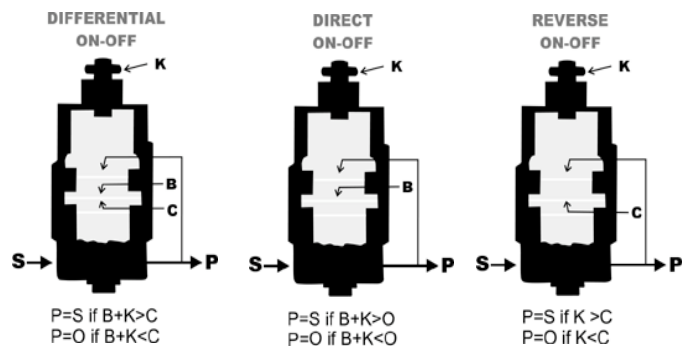

$P=A+B+C+D \pm K$ (not shown)
 $P=A+B-C+D \pm K$ (not shown)

Model 22 Computing Relay

Technical Information

Fairchild Model 22112

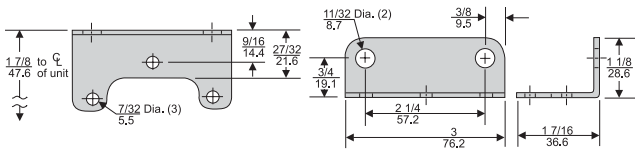
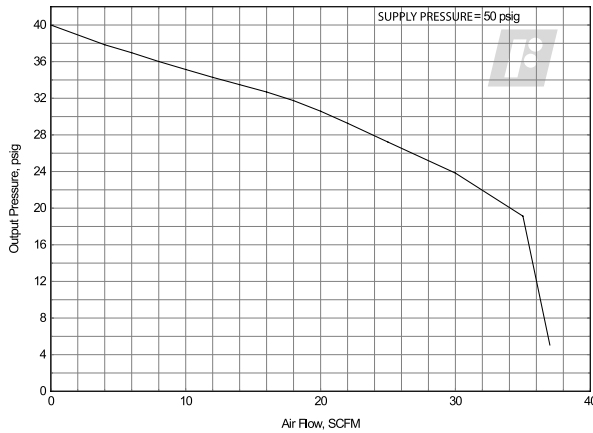

Model 22 Relay Kits & Accessories

Mounting Bracket Kit.....09921 (sold separately)

Specifications

Input and Output Pressure

3-15 psig, [-2-1.0 BAR], (20-100 kPa)

Normal Supply

20 psig, [1.5 BAR], (150 kPa)

Maximum Operating Pressure

Signal and Output: 50 psig, [3.5 BAR], (350 kPa)

Supply: 150 psig, [10.0 BAR], (1000 kPa)

Maximum Over Pressure

Any Connection: 100 psig, [7.0 BAR], (700 kPa)

Supply Connection Only: 250 psig, [17.0 BAR], (1700 kPa)

Minimum Output Pressure

0 psig at any supply pressure

Linearity of Output Pressure

Within 0.4% of full range

Supply Pressure Effect

A supply pressure change of 5 psig [.35 BAR], (35 kPa) will not change output pressure

Air Consumption (in balance of dead end service)

0.06 SCFM (.102 m³/HR) maximum at 15 psig, [1.0 BAR], (100 kPa) output

Repeatability

For unbalances within the normal pressure range, output pressure will repeat its previous value within 0.5% of full range

Output Flow Capacity (Midscale Output)

20 psig, [1.5 BAR], (150 kPa) supply. A forward flow of 2 SCFM (3.4 m³/HR) will not cause a drop in output of more than 3% of full range

Ambient Temperature Limits

-40°F to 200°F, (-40°C to 93.3°C)

Materials of Construction

Valve & BonnetDie Cast Aluminum
DiaphragmBuna A
Range Screws & FastnersZinc Plated Steel

Catalog Information

Catalog Number

2 2

Function

Totalizing	(P = A+B±K)
Differential	(P = B-C±K)
Amplifying	(P = 2A±K)
Inverting	(P = -C±K)
Totalizing Differential	(P = A+B-C±K)
Amplifying Differential	(P = 2A-C±K)
1:1 Ratio	(P = A±K)

Differential On-Off (P = S if B±K>C) or (P = O if B±K<C)

Reverse On-Off (P = S if K>C) or (P = O if K<C)

Direct On-Off (P = S if B+K>O) or (P = O if B+K<O)

Reducing (P = $\frac{B±K}{2}$)

Averaging (P = $\frac{A+B±K}{2}$)

Totalizing (P = A+B+C±K)

Totalizing (P = A+B+C+D±K)

Totalizing Differential (P = A+B-C+D±K)

11

21

22

31¹

41¹

42¹

Pipe Size

1/4" NPT

3/8" NPT

¹ 1/4" NPT Pipe Size Only

2
3

Options

Fluorocarbon Elastomers

J

SYMBOL KEY

A, B, C, D..... Signal Pressure
K..... ± Spring Bias
P..... Output Pressure
S..... Supply Pressure

Service Information

Repair parts are available for servicing the Model 22. Please refer to the *Fairchild Model 22 Installation, Operation and Maintenance Instructions*, IS-30000022.

P.S.I. Supplies Pty Ltd

Catalogue extract for:

Fairchild Model 22 Computing Relay

For further information or sales information please contact:

www.psisupplies.com.au

Ph: +61 3 9899 6444 Email: sales@psisupplies.com.au