



Features

- The Model 30BP is a high capacity back pressure regulator that relieves excess system pressure to maintain a setpoint.
- Combination of high capacity and compact size make the Model 30BP an excellent choice for a wide range of precision applications including: Precise Control of Paper Machinery Felt Guides, Supply of a Precise Repeatable Signal to a Pneumatic Clutch, or Control of Cylinder Pressure.
- The Model 30BP is sensitive to 1/4" Water Column variation which permits use in precision processes.
- Flow of up to 40 SCFM allows use in applications with high flow requirements.
- A Separate Control Chamber and Aspirator Tube isolates the diaphragm from the main flow eliminating hunting and buzzing.

Operating Principles

The Model 30BP Regulator uses the force balance principle to cause the Relief Valve to open and vent system pressure when set point is reached.

System pressure is transmitted through the Aspirator Tube to the bottom of the Diaphragm Assembly. When the range screw is adjusted for a specific set point, the Positive Bias Spring is compressed. It exerts a force on the top of the Diaphragm Assembly. As long as the pressure acting on the bottom of the Diaphragm Assembly produces a force less than the spring force acting on the top of the Diaphragm Assembly, the Relief Valve remains closed. As system pressure increases, the force on the bottom of the Diaphragm Assembly increases until it reaches the set point. As system pressure increases beyond set point, the assembly moves upward, lifting the Relief Valve from its seat and causing the system air to vent.

If system pressure decreases below set point, the decrease in pressure is transmitted through the Aspirator Tube to the bottom of the Diaphragm Assembly. The assembly moves downward and the force exerted by the range spring on the top of the Diaphragm Assembly will cause the Relief Valve to close. For more information, see cross sectional diagram.

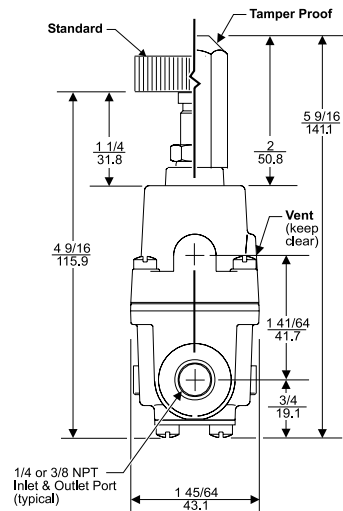
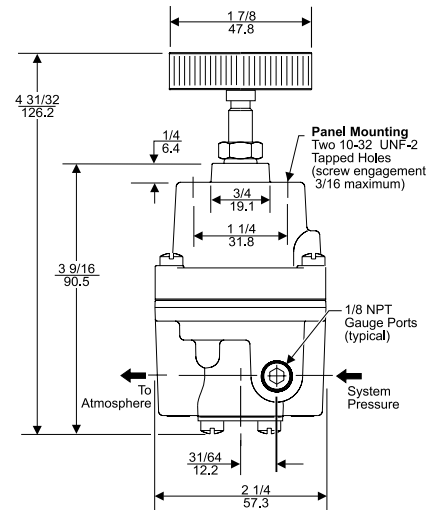
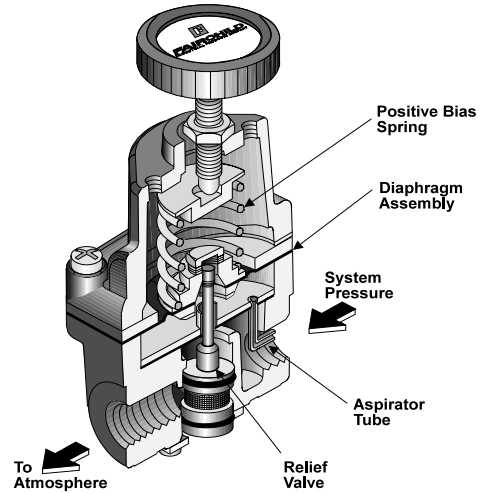

Technical Information

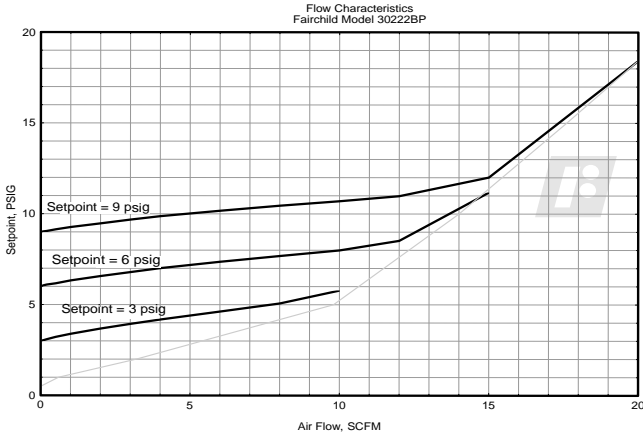

Specifications

Set Point Range

2-100 psig, [0.15-7.0 BAR], (15-700 kPa)

System Pressure (Maximum)

150 psig, [10.0 BAR], (1000 kPa)

Flow Capacity (SCFM)

40 (68 m³/HR) @ 100 psig, [7.0 BAR], (700 kPa)

Sensitivity

1/4" (.63 cm) Water Column

Ambient Temperature

-40°F to +200°F, (-40°C to 93.3°C)

Materials of Construction

Body and HousingAluminum
DiaphragmsNitrile on Dacron
TrimBrass

Catalog Information

Catalog Number 3 0 2 BP

Pressure Range

psig	[BAR]	(kPa)
0-2	[0-0.15]	(0-15)
0-10	[0-0.7]	(0-70)
.5-30	[0.03-2]	(3-200)
1-60	[0.1-4]	(10-400)
2-100	[0.15-7]	(15-700)

- 1
- 2
- 3
- 4
- 5

Pipe Size

1/4" NPT	2
3/8" NPT	3

Options

Silicone Elastomers ¹	A
Fluorocarbon (Viton) Elastomers	J
BSPP (Parallel) ²	H
Screwdriver Adjustment	S
Tamper Proof	T
BSPT (Tapered)	U

¹ Maximum System Pressure - 75 psig, [5.0 BAR], (500 kPa)

² BSPP Threads in Inlet & Outlet Ports Only. Others BSPT.

Installation

For installation instructions, refer to the *Fairchild Model 30BP Midget Precision Back Pressure Regulator Installation, Operation and Maintenance Manual*, IS-100030BP.

P.S.I. Supplies Pty Ltd

Catalogue extract for:

**Fairchild Model 30BP
Precision Back Pressure Regulator**

For further information or sales information please contact:

www.psisupplies.com.au

Ph: +61 3 9899 6444 Email: sales@psisupplies.com.au