



Features

- Maintains consistent output under pressure shock and vibration conditions.
- Temperature Compensation provides stable operation under environmental changes.
- Adjustable Positive and Negative Bias permits use with various final control elements.
- High Output Flow meets requirements for most industrial control applications.
- Adjustable Gain allows a single device to cover most industrial and process control requirements.

Operating Principles

The T5221 Transducer is an electro-pneumatic device that converts a DC current or voltage input signal to a proportional output pressure. This device is made up of four sections, the Signal Conversion Section, the Pneumatic Section, the Ratio Section, and the Booster Section.

The Signal Conversion Section (PC Board) accepts a DC current or voltage. This signal current is applied to a Coil which creates a magnetic force that moves a Flexure Arm.

The Pneumatic Section operates as a force balance system. A Sapphire Ball floats inside a Nozzle and controls the output pressure by exhausting air supplied through an Orifice. This Sapphire Ball acts as a piston exerting a force which is balanced against the force transferred to the Flexure arm by the Coil. Signal pressure from the Pneumatic Section is routed to the underside of the Signal Diaphragm in the Ratio Section. Signal pressure acting on the Signal Diaphragm transmits a force through the lever to the Control Diaphragm of the booster. The output pressure is a function of signal pressure times the ratio of lever arm lengths on either side of the Pivot.

The Booster Section supplies the unit's output pressure. At set point, the lever Arm force acting on the top of the Control Diaphragm is balanced by the force due to the booster output pressure acting on the underside of the Control Diaphragm.

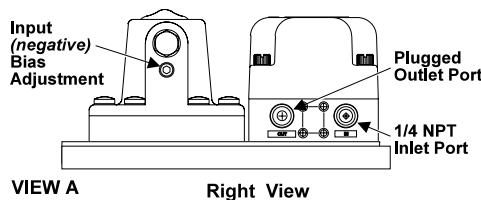
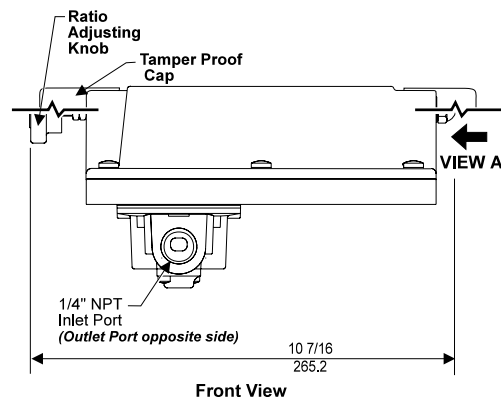
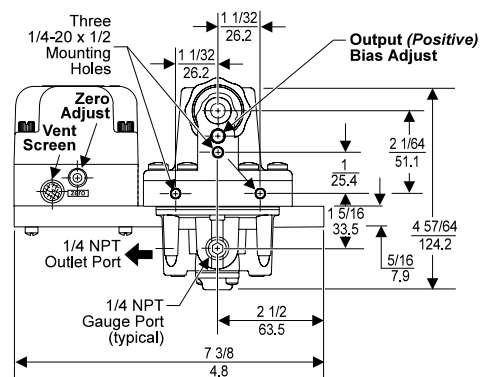
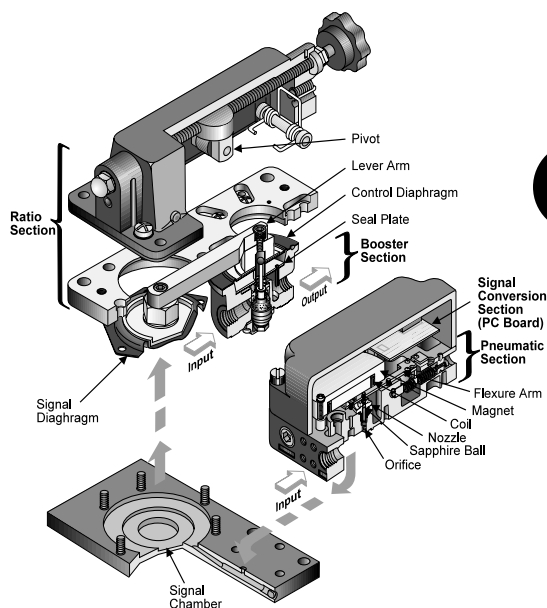

Model T5221 Electro-Pneumatic I/P, E/P Transducer

Hazardous Area Specifications

B

**Model
T5221**

Factory Mutual (FM) Approvals

Entity Parameters

Voc ¹ = 40 VDC	Ca ³ = 0 μ F
Isc ² = 200 mA	La ⁴ = 0 mH
¹ Voc = Open Circuit Voltage	³ Ca = External Capacitance
² Isc = Short Circuit Voltage	⁴ La = External Inductance

Canadian Standards Association (CSA) Approvals

Approvals are valid when connected through a Shunt Zener Diode Safety Barrier meeting the following parametric requirements:

Rated: 28V Maximum 300 Ohm Minimum



Intrinsically Safe

TFN5221
NEMA 4X Enclosure

TFI5221
Class I, Division 1, Groups A, B, C and D;
Class II, Division 1, Groups E, F and G;
Class III, Division 1; Fibers;
NEMA 3R Enclosure. **(Upright Position ONLY)**

TCI5221
Class I, Division 1, Groups A, B, C, and D;
Class II, Division 1, Groups E, F, and G;
Type 3 Enclosure;
Rated 1-5 mA, 4-20 mA, 10-50 mA,
1-5 VDC, 1-9 VDC;
Temperature Code T4A.

Specifications

Output Range

Minimum: 10" (25.4 cm) Water Column to 50" (127 cm) Water Column

Maximum: 0-150 psig, [0-10 BAR], (0-1000 kPa)

Supply Pressure

Transducer: 20 + 2 psig, [1.5 + 0.15 BAR], (150 + 15 Kpa)
Ratio Relay¹: 250 psig, [17 BAR], (1700 kPa)

Air Consumption

0.36 (0.6 m³/HR) Maximum

Output Capacity (SCFM)

40 (68 m³/HR) Maximum with 100 psig, [7 BAR], (700 kPa) Booster supply

Exhaust Capacity (SCFM)

5.5 (9.4 m³/HR) downstream pressure @ 5 psig, [.35 BAR], (35 kPa) above 20 psig, [1.5 BAR], (150 kPa) setpoint.

Supply Pressure Effect

Transducer: 1 % of Span for a + 2 psig, [.15 BAR], (15 kPa) change.

Ratio Relay: Less than 0.1 psig, [.007 BAR], (.7 kPa) for 100 psig, [7 BAR], (700 kPa) change.

¹ Supply Pressure must be no less than 10 psig, [0.7 BAR], (70 kPa) above max. booster output.

Terminal Based Linearity

+ 0.50 % Full Scale

Independent Linearity

+ 0.25 % Full Scale

RFI/EMI Effect

Less than 0.5% of Span @ 30 v/m class 3 Band ABC (20-1000 mHz) per SAMA PMC 33.1 1978 and less than 0.5% of Span @ 10 v/m level 3, 27-500 mHz Band per IEC Standard 801-3 1984. EMC Directive 89/336/EEC European Norms EN 50081-2 and EN 50082-2.

Impedence / Input Signal Range OHMS

1-5 mA	2000
4-20 mA	120 (Add 332 OHMS for CSA units)
10-50 mA	50 (Add 332 OHMS for CSA units)
1-5 VDC	375
1-9 VDC	2550

Ambient Temperature

-40 ° F to + 150 ° F, (-40 ° C to 65.5 ° C)

Materials of Construction

Body and HousingAluminum
Ball and OrificeSapphire
NozzleStainless Steel

Model T5221 Electro-Pneumatic I/P, E/P Transducer

Mounting Kits

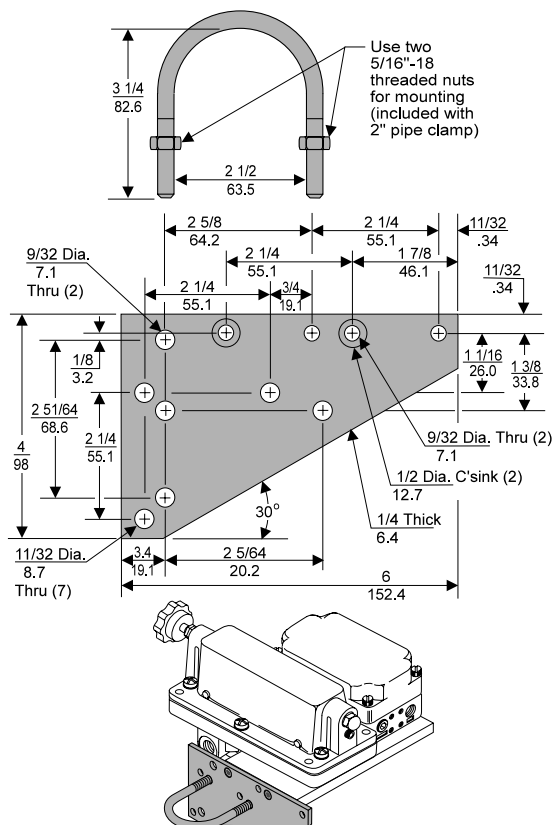

Mounting Bracket: 15307-1

Model T5221 Transducer Kits & Accessories

Mounting Bracket Kits15307-1 (included with unit)

Catalog Information

Catalog Number	T		5221			
Underwriting Group						
Canadian Standard	C					
Factory Mutual	F					
Approval Class						
Intrinsically Safe ¹		I				
Input						
1-5 mA				1		
4-20 mA				4		
10-50 mA ²						
1-5 VDC				5		
1-9 VDC				9		
Output						
psig					0	
[BAR]					1	
(kPa)					2	
Options						
Tamper Proof						T

¹ Intrinsically Safe units cannot be set for Reverse Acting Mode in field.
² Units shipped calibrated 4-20 mA; Units must be calibrated 10-50 mA in field.

Installation

For installation instructions, refer to the *Fairchild T5221 Electro-Pneumatic Transducer Installation, Operation and Maintenance Instructions, IS-500T5221*.
 For operation instructions, refer to the *Fairchild T5221 Electro-Pneumatic Transducer Installation, Operation and Maintenance Instructions, OM-500T5221*.



P.S.I. Supplies Pty Ltd

Catalogue extract for:

Fairchild Model T5221 Electro-Pneumatic I/P, E/P Transducer

For further information or sales information please contact:

www.psisupplies.com.au

Ph: +61 3 9899 6444 Email: sales@psisupplies.com.au