



Features

- Internal electronic feedback maintains precise output pressure control.
- Piezoelectric actuator disk provides stability regardless of vibration or position.
- RFI/EMI protection eliminates susceptibility to electromagnetic interference.
- Field selectable outputs in three pressure ranges match final control element requirements.
- Field reversible feature provides output that is directly or inversely proportional to input signal.
- Does not contain copper-based metals.
- Compact size for use in restricted areas.
- Damping adjustment allows tuning for optimum response.
- Optional version approved for use with Natural Gas or Industrial Methane as a supply media.
- Explosion-proof NEMA 4X, IP65, Type 4 enclosure for outdoor and indoor installations.
- Optional tapped exhaust port vents exhaust gas.
- Canadian Registration Numbers (CRN) certification for all territories and provinces.

Operating Principles

The Model TXI7800 transducer is an electronically controlled pressure sensitive device that converts a current signal to a pneumatic output. This device is composed of the Primary Converting Section and the Relay Section. The Piezoelectric ceramic disk in the Primary Section functions as a flapper. The flapper and the nozzle work together to control the signal pressure in the Relay Section. The signal pressure acts on a diaphragm assembly that controls the pressure in the output chamber.

The output pressure is sensed by the lower control diaphragm to maintain the output pressure. The output pressure is also sensed by the feedback control circuit, which compares the output pressure and input signal (setpoint) to maintain constant output pressure.

The Damping Adjustment on the PC Board allows tuning the transducer for optimum response and stability. Large downstream volumes generally require more damping to achieve output pressure stability.

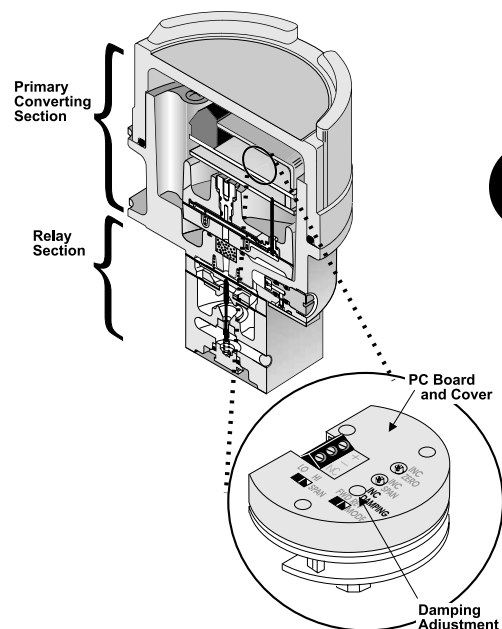

B
Model
TXI
7800

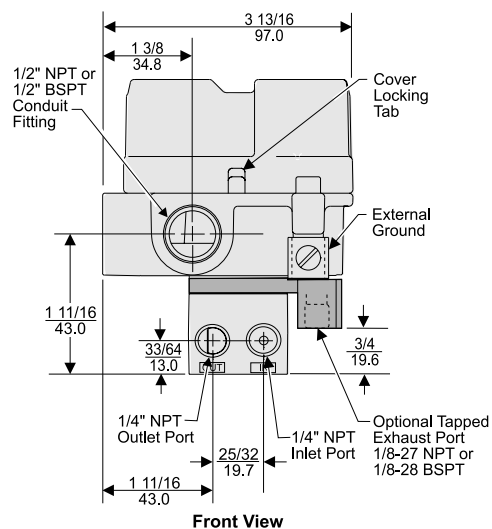
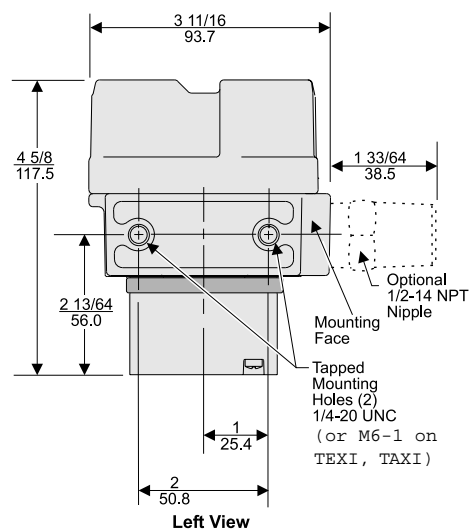

Model TXI7800 Explosion-Proof Transducer



Specifications

		SET POINT			
		3 [0.2] (20)	9 [0.6] (60)	15 [1.0] (100)	30 [2.0] (200)
Maximum Air Consumption	All Ranges SCFH	3.5 (.10 m ³ /HR)	7.0 (.20 m ³ /HR)	9.5 (.27 m ³ /HR)	13.5 (.38 m ³ /HR)
Flow Rate (SCFM)		2.5 (4.25 m ³ /HR) @ 25 psig, [1.7 BAR], (170 kPa) supply & 9 psig, [0.6 BAR], (60 kPa) Output		9.0 (15.3 m ³ /HR) @ 120 psig, [8.0 BAR], (800 kPa) supply & 9 psig, [0.6 BAR], (60 kPa) Output	
Temperature Range	Operating Storage	-40°F to +160°F (-40°C to +71.2°C) -40°F to +180°F (-40°C to +82.2°C)			
Span/Zero Adjustments		Screwdriver adjustments located under cover			
		OUTPUT RANGE			
		3-15 [0.2-1.0] (20-100)	3-27 [0.2-1.8] (20-180)	6-30 [0.4-2.0] (40-200)	
Input Range		4-20 mA			
Supply Pressure^{1,2}		20-120 [1.5-8.0] (150-800)	32-120 [2.2-8.0] (220-800)	35-120 [2.4-8.0] (240-800)	
Minimum Span		5 [0.35] (35)	10 [0.7] (70)	10 [0.7] (70)	
Frequency Response		-3 db @ 5 Hz per ISA S26.4.3.1 load configuration A.			
Required Operating Voltages		7.2 VDC @ 20 mA (4-20 mA signal)			
Accuracy (ISA S51.1)		0.25% Full Scale Guaranteed 0.15% Full Scale Typical			
Hysteresis (ISA S51.1)		<input type="checkbox"/> 0.1% Full Scale			
Deadband		<input type="checkbox"/> 0.02% Full Scale			
Repeatability (ISA S51.1)		<input type="checkbox"/> 0.1% Full Scale			
Position Effect		No Measurable Effect			
Vibration Effect		Less than +1% of Span under the following conditions: 5-15 Hz @ 0.75 inches constant displacement 15-500 Hz @ 10 Gs.			
Reverse Polarity Protection		No damage occurs from reversal of normal supply current (4-20 mA) or from misapplication of up to 60 mA.			
RFI/EMI Effect		Less than 0.5% of span @ 30 μ m class 3 Band ABC (20-1000 mHz) per SAMA PMC 33.1 1978 and less than 0.5% of Span @ 10 μ m level, to 2 GHz Band per EN 61000-4-3:1998 +A1 EMC Directive 89/336/EEC European Norms EN 61326			
Supply Pressure Effect		No Measurable Effect			
Temperature Effect		[+0.5% +0.04% / °F Temperature Change] of Span typical			
Materials of Construction		Body and HousingChromate Treated Aluminum OrificeAluminum & Sapphire TrimStainless Steel & Zinc Plated Steel ElastomersNitrile FinishEpoxy Powder Coating			

¹ Supply Pressure must be no less than 5 psig, [0.35 BAR], (35 kPa), above maximum output.

² Atex Approved unit 40 psig, [2.8 BAR], (280 kPa). Atex Approved unit with "N" option 120 psig, [8.0 BAR], (800 kPa) for Air or Group IIA gases.

Hazardous Area Classifications

	Explosion-Proof	Intrinsically Safe										
Factory Mutual (FM) Approvals 	<p>Air as supply pressure media Class I, Division 1, Groups B, C and D; Class II, Division 1, Groups E, F and G; Class III, Division 1, Fibers; Class I, Division 2, Groups A, B, C and D; NEMA 4X Enclosure; Max. Ambient 65°C; Temperature Code T5.</p> <p>Group D gases, including Natural Gas as supply pressure media Class I, Division 1, Groups C and D; Class II, Division 1, Groups E, F and G; Class I, Division 2, Groups A, B, C and D; Class II, Division 2, Groups E, F and G.</p>	<p>Air as supply pressure media Class I, Division I, Groups C and D; Class II, Division 1, Groups E, F and G; Class III, Division 1; Fibers; NEMA 4X Enclosure; Max. Ambient 65°C; Temperature Code T4.</p> <table border="1" style="width: 100%; border-collapse: collapse;"> <thead> <tr> <th colspan="2" style="text-align: left;">Entity Parameters</th> </tr> </thead> <tbody> <tr> <td style="width: 50%;">V_{max}¹ = 30 VDC</td> <td style="width: 50%;">C_i³ = 0 □ F</td> </tr> <tr> <td>I_{max}² = 200 mA</td> <td>L_i⁴ = 0 mH</td> </tr> <tr> <td>¹V_{max} = Max. Voltage</td> <td>³C_i = Capacitance</td> </tr> <tr> <td>²I_{max} = Max. Current</td> <td>⁴L_i = Inductance</td> </tr> </tbody> </table>	Entity Parameters		V _{max} ¹ = 30 VDC	C _i ³ = 0 □ F	I _{max} ² = 200 mA	L _i ⁴ = 0 mH	¹ V _{max} = Max. Voltage	³ C _i = Capacitance	² I _{max} = Max. Current	⁴ L _i = Inductance
Entity Parameters												
V _{max} ¹ = 30 VDC	C _i ³ = 0 □ F											
I _{max} ² = 200 mA	L _i ⁴ = 0 mH											
¹ V _{max} = Max. Voltage	³ C _i = Capacitance											
² I _{max} = Max. Current	⁴ L _i = Inductance											
Canadian Standards Association (CSA) Approvals 	<p>Air as supply pressure media Class I, Division 1, Groups B, C and D; Class II, Division 1, Groups E, F and G; Class I, Division 2, Groups A, B, C and D; Class II, Division 2, Groups E, F and G. Type 4X Enclosure; Temperature Code T5; Max. Ambient 65°C.</p> <p>Group D gases, including Natural Gas as supply pressure media Class I, Division 1, Groups C and D; Class II, Division 1, Groups E, F and G; Class I, Division 2, Groups A, B, C and D. Class II, Division 2, Groups E, F and G.</p>	<p>Air as supply pressure media Class I, Division 1, Groups C and D; Class II, Division 1, Groups E, F and G; Type 4X Enclosure; Temperature Code T4; Rated 4-20 mA, 30 VDC maximum.</p> <table border="1" style="width: 100%; border-collapse: collapse;"> <thead> <tr> <th colspan="2" style="text-align: left;">Approvals are valid when connected through a Shunt Zener Diode Safety Barrier meeting the following parametric requirements:</th> </tr> </thead> <tbody> <tr> <td style="width: 30%;">System Type 1:</td> <td>Single Channel Polarized Rated: 28.5V Max. 300 Ohm Min.</td> </tr> <tr> <td>System Type 2:</td> <td>Dual Channel Polarized Rated 28.5V Max. 300 Ohm Min. and 28V Diode return per channel</td> </tr> <tr> <td>System Type 3:</td> <td>Dual Channel Polarized Rated: 28.5V Max. 300 Ohm Min. and 10V Max. 50 Ohm Min.</td> </tr> </tbody> </table>	Approvals are valid when connected through a Shunt Zener Diode Safety Barrier meeting the following parametric requirements:		System Type 1:	Single Channel Polarized Rated: 28.5V Max. 300 Ohm Min.	System Type 2:	Dual Channel Polarized Rated 28.5V Max. 300 Ohm Min. and 28V Diode return per channel	System Type 3:	Dual Channel Polarized Rated: 28.5V Max. 300 Ohm Min. and 10V Max. 50 Ohm Min.		
Approvals are valid when connected through a Shunt Zener Diode Safety Barrier meeting the following parametric requirements:												
System Type 1:	Single Channel Polarized Rated: 28.5V Max. 300 Ohm Min.											
System Type 2:	Dual Channel Polarized Rated 28.5V Max. 300 Ohm Min. and 28V Diode return per channel											
System Type 3:	Dual Channel Polarized Rated: 28.5V Max. 300 Ohm Min. and 10V Max. 50 Ohm Min.											
	Flame-Proof	Intrinsically Safe										
Explosive Atmospheres Directive (ATEX) Approvals*	<p>Air as supply pressure media Ⓢ II 2 GD EEx d IIB + H₂, T5 (-20°C to +65°C) Ambient; IP65 Enclosure.</p> <p>Group IIA gases, including Natural Gas as supply pressure media Ⓢ II 2 GD EEx d IIB, T5 (-20°C to +65°C) Ambient; IP65 Enclosure.</p>	<p>Air as supply pressure media Ⓢ II 1 G (T4) II1D (T 85°C) EEx ia IIB, T4 (-20°C to +72°C) Ambient; IP65 Enclosure.</p>										
Standards Australia (SAA) Approvals*	<p>Air as supply pressure media Ex d IIB + H₂, T5 (-20°C to +65°C) Ambient; IP65 Enclosure.</p>	<p>Air as supply pressure media Ex ia IIB, T4 (-20°C to +72°C) Ambient.</p>										

B

Model
TXI
7800

*** Transducer Parameters**

U _{max} ¹ = 28 V	P _i ³ = 0.7 W	L _i ⁵ = 0
I _{max} ² = 100 mA	C _i ⁴ = 0	
¹ U _{max} = Max. Voltage	³ P _i = Max. Power	⁵ L _i = Inductance
² I _{max} = Max. Current	⁴ C _i = Capacitance	

Model TXI7800 Explosion-Proof Transducer

Mounting Kit

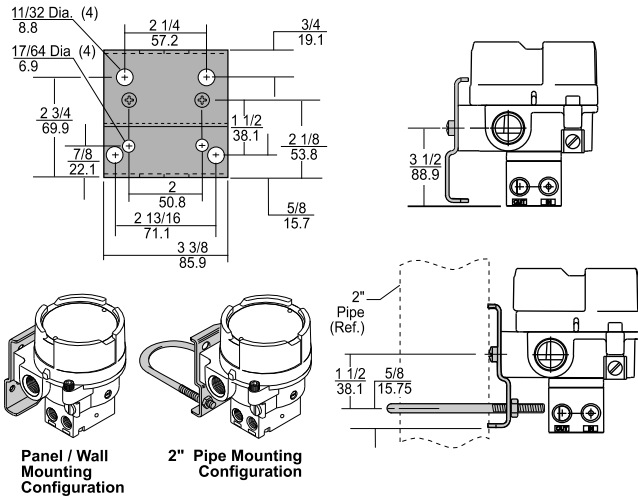

B

Model TXI 7800

Model TXI7800 Transducer Kits & Accessories

Mounting Bracket Kits19021-1: TCXI7800, TFXI7800 (sold separately)
 19021-2: TEXI7800, TAXI7800 (sold separately)

Catalog Information

Catalog Number T X I 7800

Underwriting Group

SAA
 Canadian Standard
 ATEX
 Factory Mutual

A
C
E
F

Input

4-20 mA 4

Output

3-15 psig	01
3-27 psig	02
6-30 psig	03
0-30 psig ⁴	04
0-60 psig ⁴	05
0-120 psig ⁴	06
[0.2-1.0 BAR]	11
[0.2-1.8 BAR]	12
[0.4-2.0 BAR]	13
[0-2.0 BAR] ⁴	14
[0-4.0 BAR] ⁴	15
[0-8.0 BAR] ⁴	16
(20-100 kPa)	21
(20-180 kPa)	22
(40-200 kPa)	23
(0-200 kPa) ⁴	24
(0-400 kPa) ⁴	25
(0-800 kPa) ⁴	26

Options

Tapped Exhaust	E
Natural Gas media approval, Group D gases	N
(Includes Nipple; TCXI, TEXI, TFXI only) ^{1,2}	
BSPT Thread ³	U

¹ Not approved for Intrinsically Safe.

² Tapped Exhaust option required.

³ Available for ATEX and SAA only. NOT available with "N" Option.

⁴ Consult Factory for details and availability.

Installation

For installation instructions, refer to the *Fairchild Model TXI7800 Explosion-proof Electro-pneumatic Transducer Installation, Installation Instructions, II-5TXI7800.*

For operation and maintenance instructions, refer to the *Fairchild Model TXI7800 Explosion-proof Electro-pneumatic Transducer Operation and Maintenance Instructions, OM-5TXI7800.*

P.S.I. Supplies Pty Ltd

Catalogue extract for:

Fairchild Model TXI7800 Explosion-Proof Transducer

For further information or sales information please contact:

www.psisupplies.com.au

Ph: +61 3 9899 6444 Email: sales@psisupplies.com.au